

# Town of Chino Valley

## Survey Control Network Report

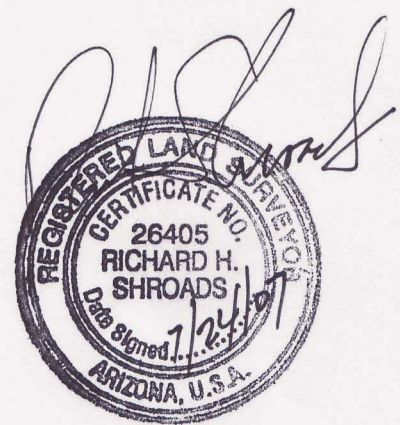

2050 N. Willow Creek Road  
Prescott AZ 86301  
928-771-2376



# Table of Contents

## “Town of Chino Valley Survey Datum Outline”

A short outline of how the data for the Town of Chino Valley and it’s GPS system has been developed.

## “Converting between NAD 1983 Survey Data and Chino Valley Survey Datum (CVSD)”

A description of the steps to take in order to convert NAD83 data (state plane grid) to Chino Valley Survey Datum (on the ground).

## “Survey Monument Record Details”

This section has the following data for each of the 10 Town Reference Point Monument Records:

1. Monument Field Visit Information
2. Corner Tie and Location Sketch
3. Satellite Obstruction Chart
4. Site photographs

## “Town of Chino Valley Survey Datum Conversion Spreadsheet”

This section consists of a spreadsheet that lists all of the coordinates for each of the Control Points. Listed are NAD83 epoch 2002 Latitude/ Longitude, State Plane Grid (Arizona Central zone) coordinates international feet, and CVSD coordinates (Local Datum at Ground values).

## “Control Monument Location Map”

This is a vicinity map showing the approximate locations of the Town’s control points scattered throughout the Town and surrounding area.

# Town of Chino Valley

## SURVEY DATUM NARRATIVE

## TOWN OF CHINO VALLEY SURVEY DATUM NARRATIVE

A static GPS network survey was performed in April of 2007 of twelve reference points in the Chino Valley area. Ten of these points are generally surrounding Chino Valley, one point is located to the northwest of the Town, and one point is located to the southeast of the Town. The GPS static network utilized three nearby CORS stations for base control. All CORS stations used have been established utilizing the NAD83 (2002) horizontal control and NAVD88 vertical control. The static GPS network was performed with Trimble GPS survey equipment and adjusted using Trimble Geomatics least squares adjustment routines with 99% confidence limits. NAD83 geodetic coordinates and State Plane (AZ Central zone 0202) were derived.

Three existing NGS monuments have been included in this network and have been assigned coordinate values for the Chino Valley Survey Datum. These NGS monuments are Prescott North Base Reset (PID ET0892), COTT (PID ET0893), and Prescott South Base (PID ET1887). State Plane Coordinates established for those points herein differ from the previously established NGS State Plane Coordinates.

An average elevation of the Town was derived from modeling the USGS Digital Elevation Models (DEM's) within Town limits. An average elevation of 4743 above MSL (NAVD88) was calculated using this methodology.

A Town centroid was calculated by creating a closed polyline of the town boundary, and utilizing AutoCad 2002 centroid function to derive the state plane coordinates of said centroid. A combined scale factor was calculated based on the average Town elevation (sea level scale factor) and the centroid location (mapping projection scale factor) and is utilized in the calculations herein.

It is the desire of Town officials to use this coordinate system in the Town of Chino Valley for future mapping projects.

The Town has adopted a requirement that all future development projects shall be tied into this system. This system is not intended to replace the Public Land Survey system. It is intended to supplement it and allow for the easy conversion of data into and out of the Town's Geographic Information System (GIS). The specific requirements for survey ties for new development projects are available on the Development home page on the Town's web site.

# Converting between NAD 1983 Survey Data and Chino Valley Survey Datum (CVSD)



## TOWN OF CHINO VALLEY SURVEY DATUM CONVERSION METHODS

**Coordinate Units:** International Feet (ift)  
**Distance Units:** International Feet (ift)  
**Ellipsoid Height Units:** International Feet (ift)  
**Vertical Datum:** NAVD 88  
**Otrhometric Height Units:** International Feet (ift)

**State Plane:**  
**Coordinate System:** US State Plane 1983  
**Datum:** NAD '83 (2002)  
**Zone:** Arizona Central 0202  
**Geoid Model:** GEOID03 (Conus)

**To convert from State Plane (grid – NAD '83 epoch 2002) coordinates to Town of Chino Valley coordinates (ground):**

**Northing:** (State Plane x 1.0002970869) – 1,000,000  
**Easting:** (State Plane x 1.0002970869) – 400,000

**Example: Given State Plane coordinates:**

$N_{\text{State Plane}} = 1,346,331.865 \text{ ift}$   
 $E_{\text{State Plane}} = 549,153.180 \text{ ift}$

**Town of Chino Valley ground coordinates are derived as follows:**

$N_{\text{CVSD}} = (1,346,331.865 \times 1.0002970869) - 1,000,000 = 346,731.843 \text{ ift}$   
 $E_{\text{CVSD}} = (549,153.180 \times 1.0002970869) - 400,000 = 149,316.326 \text{ ift}$

**To convert from Town of Chino Valley Survey Datum (ground) coordinates to State Plane (grid – NAD '83 epoch 2002) coordinates:**

**Northing:** (CVSD + 1,000,000) x 0.9997030013

**Easting:** (CVSD + 400,000) x 0.9997030013

**Example: CVSD coordinates:**

$N_{CVSD} = 412,850.617$  ift

$E_{CVSD} = 134,876.818$  ift

**State Plane (grid) coordinates are derived as follows:**

$N_{State\ Plane} = (412,850.617 + 1,000,000) \times 0.9997030013 = 1,412,431.002$  ift

$E_{State\ Plane} = (134,876.818 + 400,000) \times 0.9997030013 = 534,717.960$  ift

**Town Centroid (NAD '83):**

34° 45' 30.8813" N lat.

112° 24' 41.12111" W long.

**Town Average Elevation:**

4,743 feet above MSL (NAVD 88)

# SURVEY MONUMENT RECORD DETAILS



**TOWN OF CHINO VALLEY CONTROL NETWORK**

**POINT NAME: 100**

**MONUMENT FIELD VISIT INFORMATION**

DATE OF FIELD VISIT 4/26/2007

LEFT AS FOUND     FOUND & TAGGED     FOUND & REBUILT     RESTORED LOST CORNER  
 RESTORED OBLITERATED CORNER     ESTABLISHED NEW MONUMENT

ARIZONA STATE PLANE COORDINATE SYSTEM:

ZONE:     WEST     CENTRAL     EAST

N.A.D. 1927 (FEET)     N.A.D. 1983 (FEET)     W.G.S. 1984 (METERS)

N.A.V.D. 1929 (FEET)     N.A.V.D. 1988 (FEET)    ELLIPSOID HEIGHT 4807.917

N. (OR) Y = 1354314.992    E. (OR) X = 576239.258    ELEVATION 4892.76

LATITUDE 34°43'18.59808"N    LONGITUDE 112°19'42.74290"W    GRID FACTOR \_\_\_\_\_

CONTROL STATIONS USED: AZAH, AZPE, FST1

DESCRIBE ALL EVIDENCE FOUND, INCLUDING TIES AND ACCESSORIES TO COMPLY WITH ARIZONA REVISED STATUTE TITLE 33, SECTION 106

**STATIC OBSERVATION 99% CONFIDENCE LEVEL**

**SEE THE TOWN OF CHINO VALLEY CONTROL NETWORK DATUM DEFINITION FOR COMBINED GRID FACTOR AND THE NORTHING AND EASTING OFFSET INFORMATION.**

**MONUMENT CAP STAMPING**

**CORNER LOCATION INFORMATION**

TOWNSHIP 16 N    RANGE 1 W

SECTION 35

GILA & SALT RIVER    MERIDIAN YAVAPAI    COUNTY

FORMAL MONUMENT NAME 100

ALIQUOT GOV'T COR.     NON-ALIQUOT GOV'T COR.     OTHER

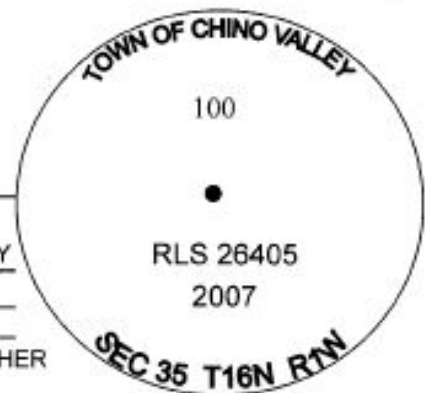



TOWN OF CHINO VALLEY CONTROL NETWORK

OBSTRUCTION CHART

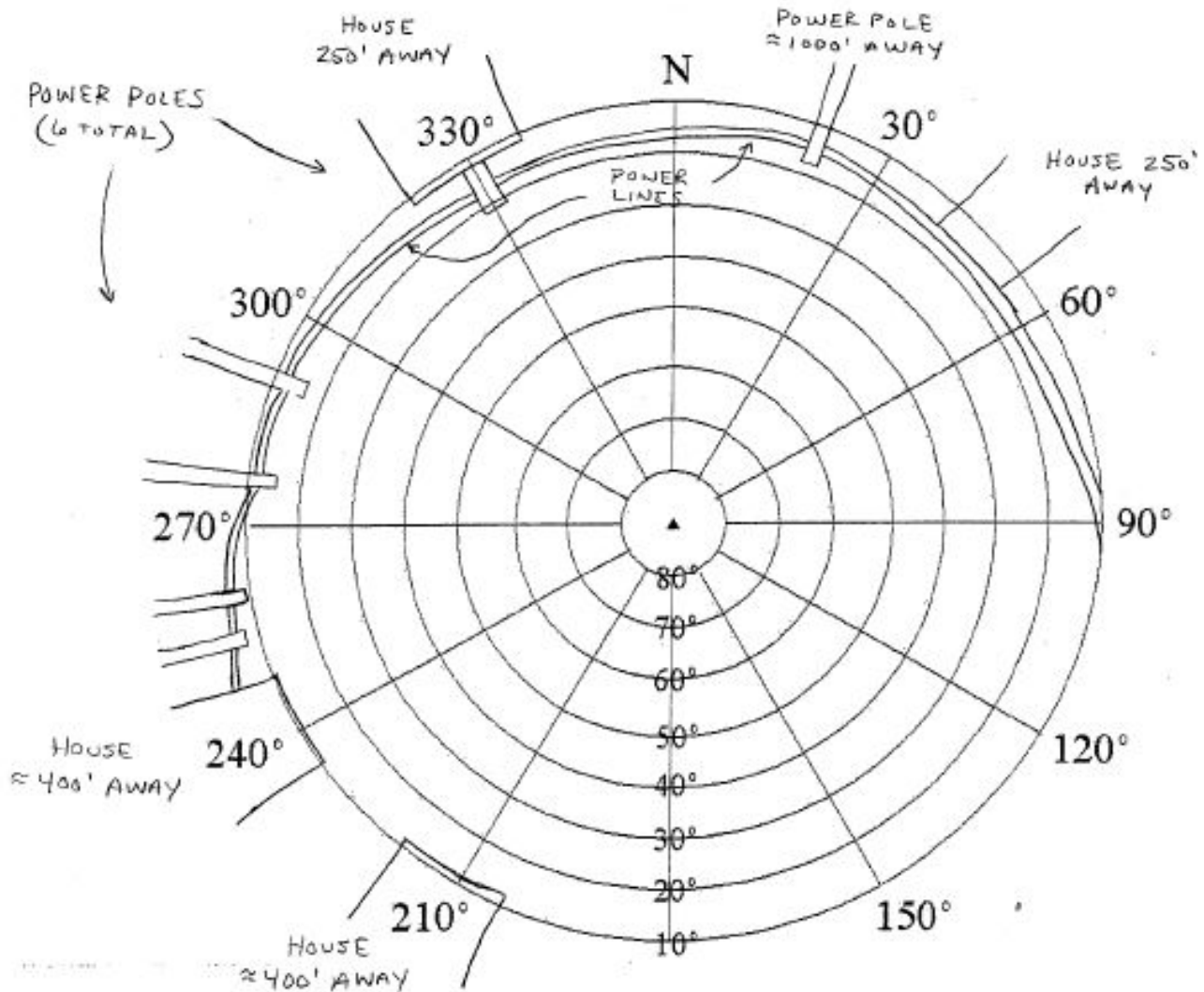

POINT # 100

DATE: 04/26/07

INSTRUCTIONS:

Identify obstructions by azimuth (magnetic) and elevation angle (above horizon) as seen from the point. Indicate distance and direction to nearby structures and reflective surfaces (potential multipath sources).

Check if no obstructions above 10 degrees









North



South



East



West

**TOWN OF CHINO VALLEY CONTROL NETWORK**

**POINT NAME: 101**

**MONUMENT FIELD VISIT INFORMATION**

DATE OF FIELD VISIT 4/26/2007  
 LEFT AS FOUND     FOUND & TAGGED     FOUND & REBUILT     RESTORED LOST CORNER  
 RESTORED OBLITERATED CORNER     ESTABLISHED NEW MONUMENT

ARIZONA STATE PLANE COORDINATE SYSTEM:

ZONE:     WEST     CENTRAL     EAST  
 N.A.D. 1927 (FEET)     N.A.D. 1983 (FEET)     W.G.S. 1984 (METERS)  
 N.A.V.D. 1929 (FEET)     N.A.V.D. 1988 (FEET)    ELLIPSOID HEIGHT 4746.354  
N. (OR) Y = 1363150.624    E. (OR) X = 529639.768    ELEVATION 4832.116  
LATITUDE 34°44'43.75442"N    LONGITUDE 112°29'01.61447"W    GRID FACTOR \_\_\_\_\_  
CONTROL STATIONS USED: AZAH, AZPE, FST1

DESCRIBE ALL EVIDENCE FOUND, INCLUDING TIES AND ACCESSORIES TO COMPLY WITH ARIZONA REVISED STATUTE TITLE 33, SECTION 106

STATIC OBSERVATION 99% CONFIDENCE LEVEL

SEE THE TOWN OF CHINO VALLEY CONTROL NETWORK DATUM DEFINITION FOR COMBINED GRID FACTOR AND THE NORTHING AND EASTING OFFSET INFORMATION.

MONUMENT CAP STAMPING

**CORNER LOCATION INFORMATION**

TOWNSHIP 16 N    RANGE 2 W  
SECTION 29  
GILA & SALT RIVER    MERIDIAN YAVAPAI    COUNTY  
FORMAL MONUMENT NAME 101

ALIQUOT GOV'T COR.     NON-ALIQUOT GOV'T COR.     OTHER

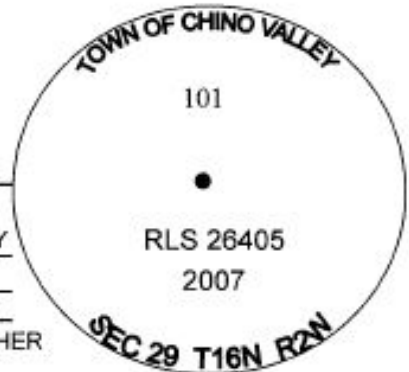



**POINT # 101**

**DATE: April 26, 2007**

**DIRECTIONS:**

- From the intersection of Hwy 89 and 89A head NORHT on Hwy 89 7.9 miles to Center St.
- Turn WEST (left) for 1.7 miles to Reed Rd.
- Monument is a 3/4 inch aluminum disk flush set in concrete in southwest return, 65ft southwest of centerline brass cap, 22ft southwest of edge of pavement and 7.8ft northeast of fence.

**SKETCH**

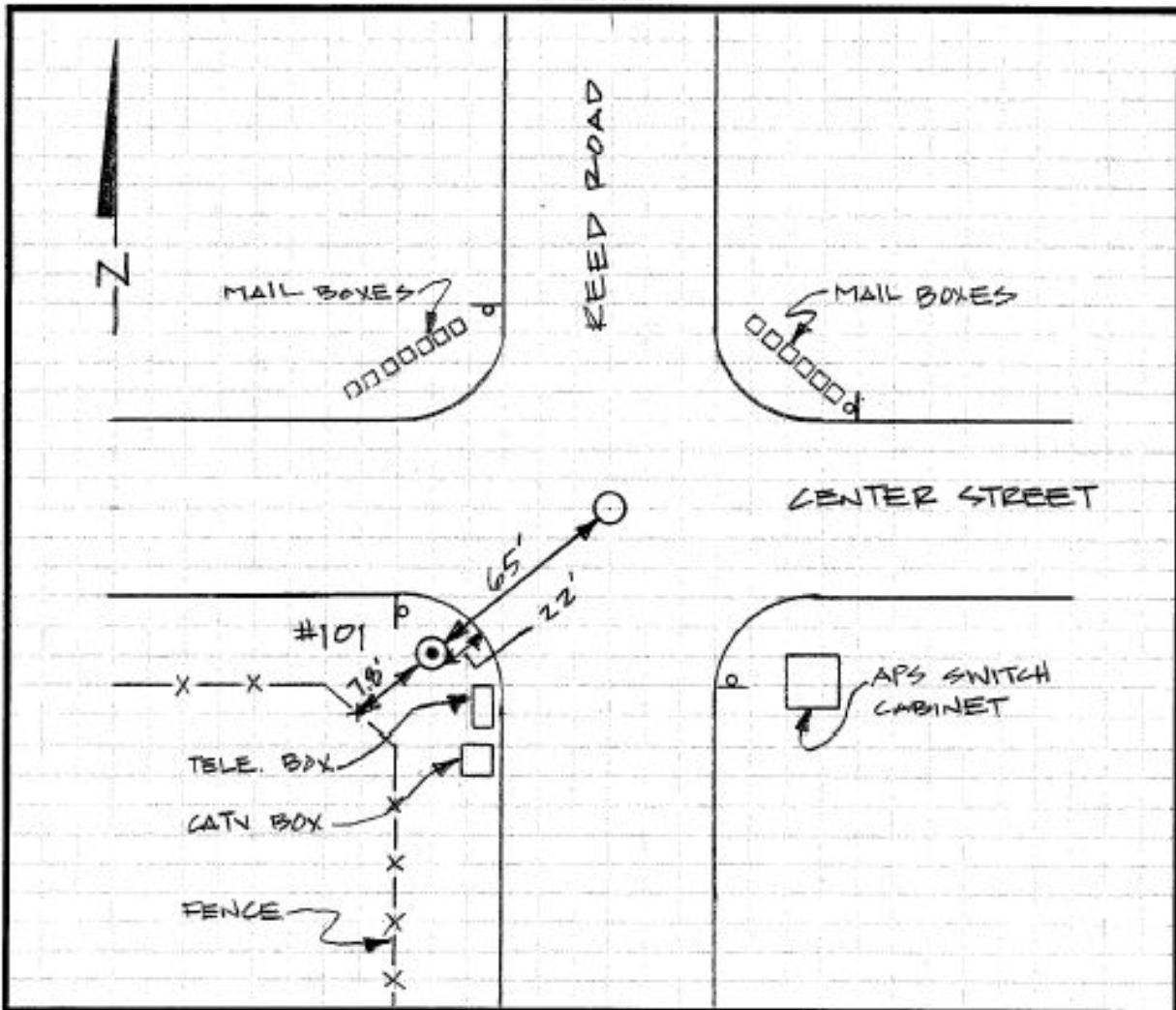



TOWN OF CHINO VALLEY CONTROL NETWORK

OBSTRUCTION CHART

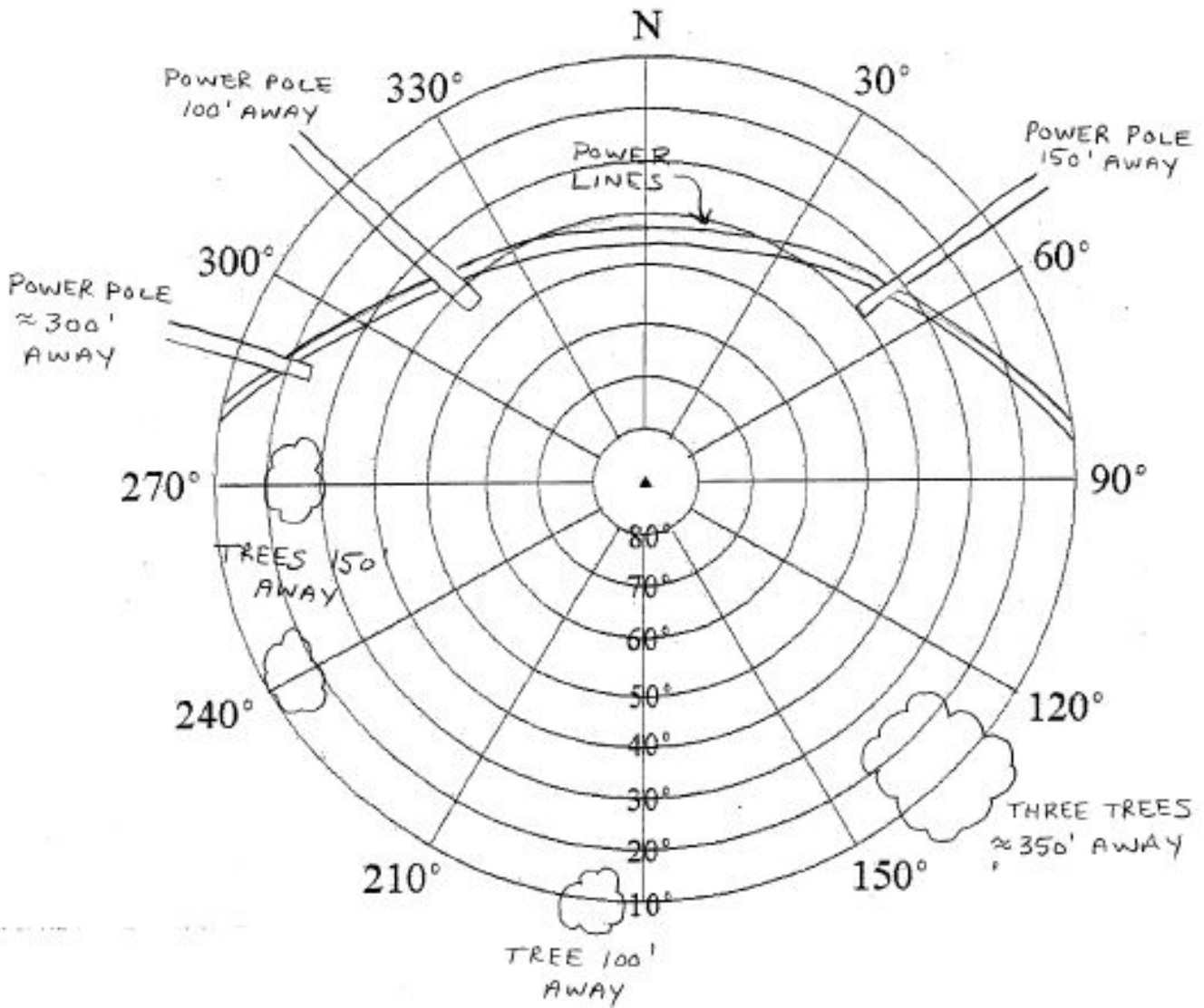

POINT # 101

DATE: 04/26/07

INSTRUCTIONS:

Identify obstructions by azimuth (magnetic) and elevation angle (above horizon) as seen from the point. Indicate distance and direction to nearby structures and reflective surfaces (potential multipath sources).

Check if no obstructions above 10 degrees







North



South





East



West

**TOWN OF CHINO VALLEY CONTROL NETWORK**

**POINT NAME: 102**

**MONUMENT FIELD VISIT INFORMATION**

DATE OF FIELD VISIT 4/26/2007

LEFT AS FOUND     FOUND & TAGGED     FOUND & REBUILT     RESTORED LOST CORNER  
 RESTORED OBLITERATED CORNER     ESTABLISHED NEW MONUMENT

ARIZONA STATE PLANE COORDINATE SYSTEM:

ZONE:     WEST     CENTRAL     EAST

N.A.D. 1927 (FEET)     N.A.D. 1983 (FEET)     W.G.S. 1984 (METERS)

N.A.V.D. 1929 (FEET)     N.A.V.D. 1988 (FEET)

ELLIPSOID HEIGHT 4728.209

N. (OR) Y = 1365811.867

E. (OR) X = 551132.245

ELEVATION 4813.536

LATITUDE 34°45'11.20221"N

LONGITUDE 112°24'44.21281"W

GRID FACTOR \_\_\_\_\_

CONTROL STATIONS USED: AZAH, AZPE, FSTI

DESCRIBE ALL EVIDENCE FOUND, INCLUDING TIES AND ACCESSORIES TO COMPLY WITH ARIZONA REVISED STATUTE TITLE 33, SECTION 106

STATIC OBSERVATION 99% CONFIDENCE LEVEL

SEE THE TOWN OF CHINO VALLEY CONTROL NETWORK DATUM DEFINITION FOR COMBINED GRID FACTOR AND THE NORTHING AND EASTING OFFSET INFORMATION.

MONUMENT CAP STAMPING

**CORNER LOCATION INFORMATION**

TOWNSHIP 16 N RANGE 2 W  
SECTION 24  
GILA & SALT RIVER MERIDIAN YAVAPAI COUNTY  
FORMAL MONUMENT NAME 102

ALIQUOT GOV'T COR.     NON-ALIQUOT GOV'T COR.     OTHER

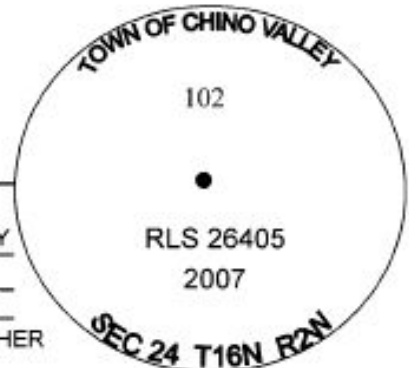

**POINT # 102**

**DATE: APRIL 26, 2007**

**DIRECTIONS:**

- From the intersection of Hwy 89 and 89A head NORTH on Hwy 89 for 9.6 miles to Perkinsville Rd.
- Turn EAST (right) for 2.3 miles to M.A. Perkins.
- Turn SOUTH (right) for 1 mile. Road bears southeast and becomes 7 Bar Rd, +/- 300 feet turn WEST (right) onto Road 2 North for +/- 300 feet cross fenceline and turn SOUTH (left) onto path for 0.5 mile
- Monument is 3 1/4 inch aluminum disk flush set in concrete, +/-110 feet northwest of fence intersection and section 24 east 1/4 corner, +/- 75 feet south of east-west fence and +/- 75 feet west of north-south fence

**SKETCH**

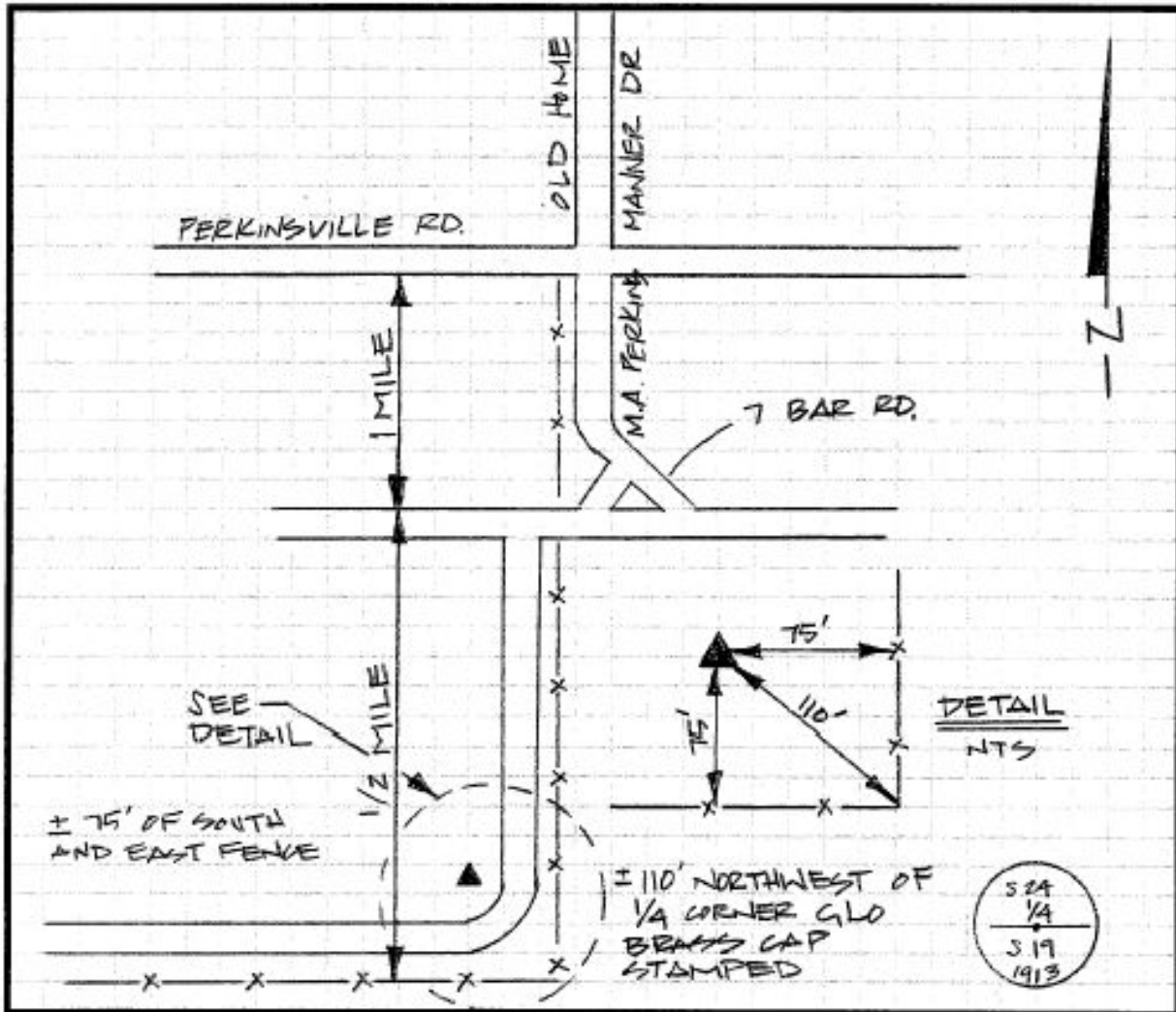

TOWN OF CHINO VALLEY CONTROL NETWORK

OBSTRUCTION CHART

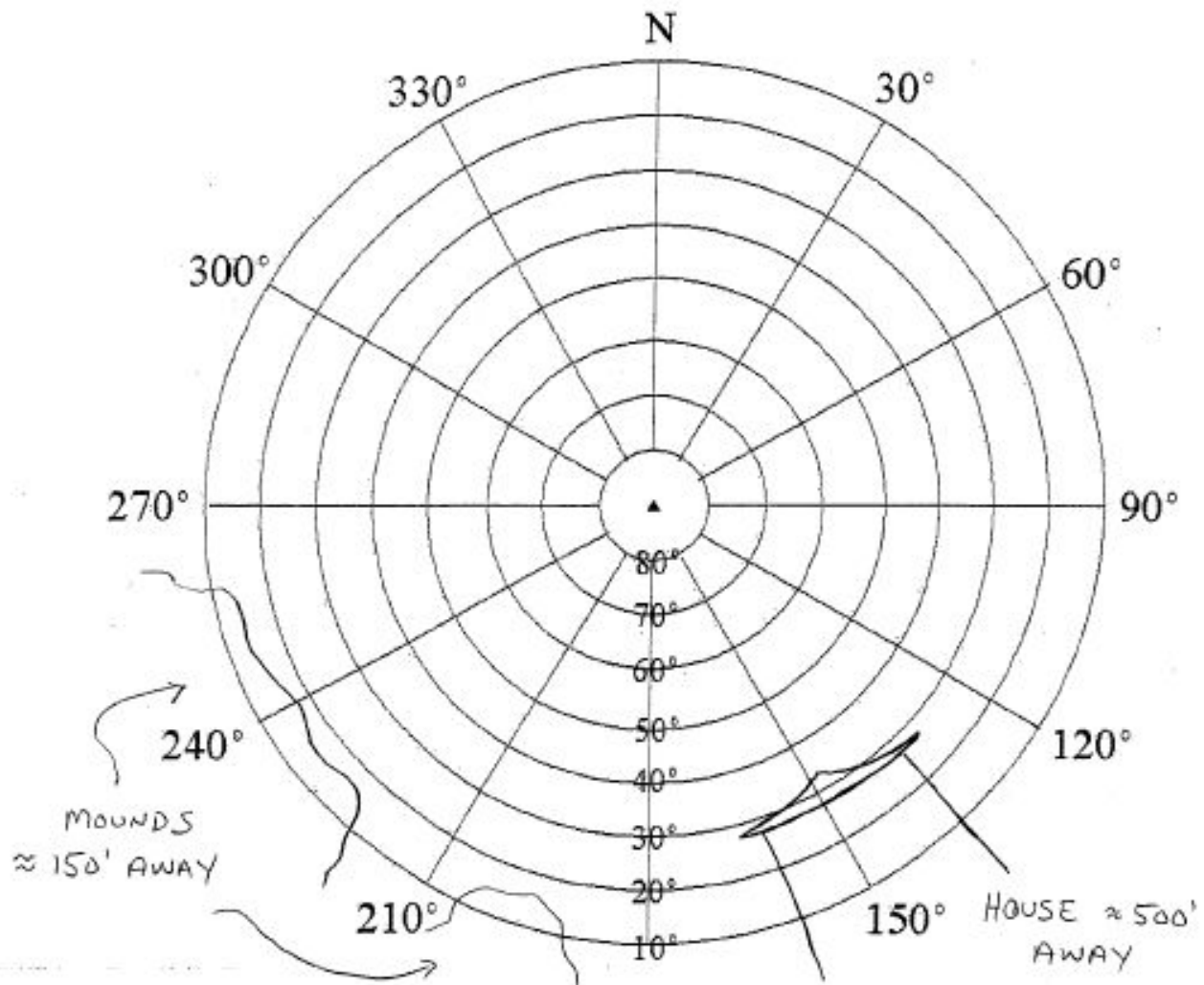

POINT # 102

DATE: 04/26/07

INSTRUCTIONS:

Identify obstructions by azimuth (magnetic) and elevation angle (above horizon) as seen from the point. Indicate distance and direction to nearby structures and reflective surfaces (potential multipath sources).

Check if no obstructions above 10 degrees









North



South

**TOWN OF CHINO VALLEY CONTROL NETWORK**

**POINT NAME: 103**

**MONUMENT FIELD VISIT INFORMATION**

DATE OF FIELD VISIT 4/26/2007  
 LEFT AS FOUND  FOUND & TAGGED  FOUND & REBUILT  RESTORED LOST CORNER  
 RESTORED OBLITERATED CORNER  ESTABLISHED NEW MONUMENT

ARIZONA STATE PLANE COORDINATE SYSTEM:

ZONE:  WEST  CENTRAL  EAST  
 N.A.D. 1927 (FEET)  N.A.D. 1983 (FEET)  W.G.S. 1984 (METERS)  
 N.A.V.D. 1929 (FEET)  N.A.V.D. 1988 (FEET) ELLIPSOID HEIGHT 4655.057  
N. (OR) Y = 1379154.752 E. (OR) X = 561692.789 ELEVATION 4739.856  
LATITUDE 34°47'23.68341"N LONGITUDE 112°22'38.37938"W GRID FACTOR \_\_\_\_\_  
CONTROL STATIONS USED: AZAH, AZPE, FST1

DESCRIBE ALL EVIDENCE FOUND, INCLUDING TIES AND ACCESSORIES TO COMPLY WITH ARIZONA REVISED STATUTE TITLE 33, SECTION 106

STATIC OBSERVATION 99% CONFIDENCE LEVEL

SEE THE TOWN OF CHINO VALLEY CONTROL NETWORK DATUM DEFINITION FOR COMBINED GRID FACTOR AND THE NORTHING AND EASTING OFFSET INFORMATION.

MONUMENT CAP STAMPING

**CORNER LOCATION INFORMATION**

TOWNSHIP 16 N RANGE 1 W  
SECTION 5  
GILA & SALT RIVER MERIDIAN YAVAPAI COUNTY  
FORMAL MONUMENT NAME 103

ALIQUOT GOVT COR.  NON-ALIQUOT GOVT COR.  OTHER

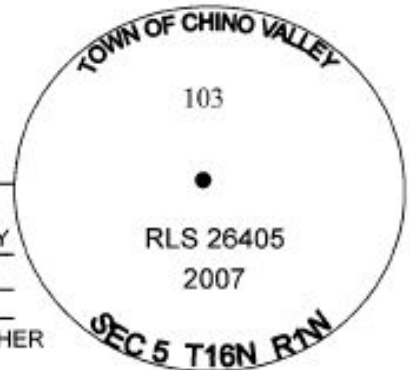

**POINT # 103**

**DATE: APRIL 26, 2007**

**DIRECTIONS:**

- From the intersection of Hwy 89 and 89A head NORTH on Hwy 89 for 9.6 miles to Perkinsville Rd.
- Turn EAST (right) for 4.5 miles to Haystack Ranch Road.
- Turn NORTH (left) for 0.5 mile, at "Y" bear left continue for 1.1 miles to point on west side of road
- Monument is 3 1/4 inch aluminum cap set in concrete up 0.8 of a foot, 10 feet east of small rock outcrop, +/-100 north northwest of the section corner at fence intersection

**SKETCH**

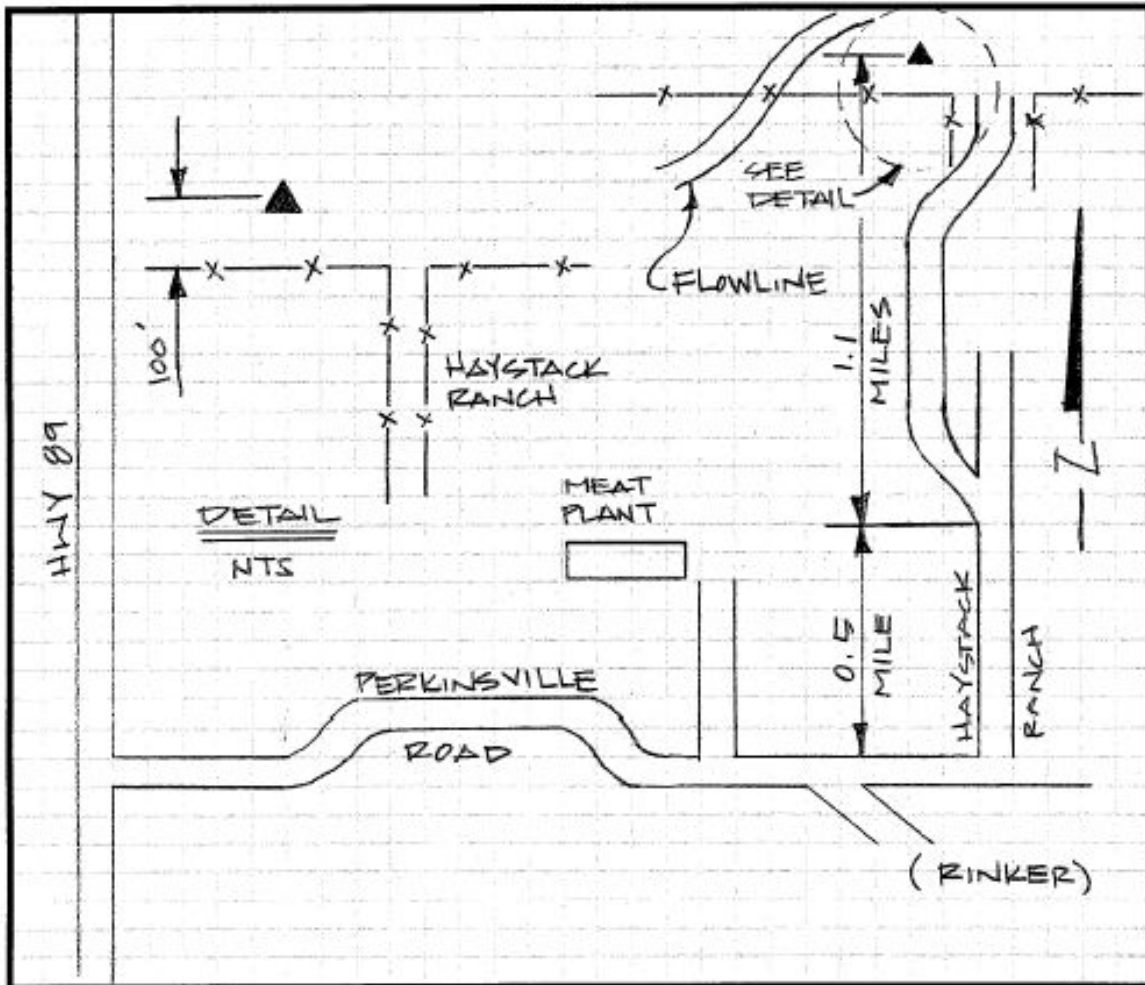

TOWN OF CHINO VALLEY CONTROL NETWORK

OBSTRUCTION CHART

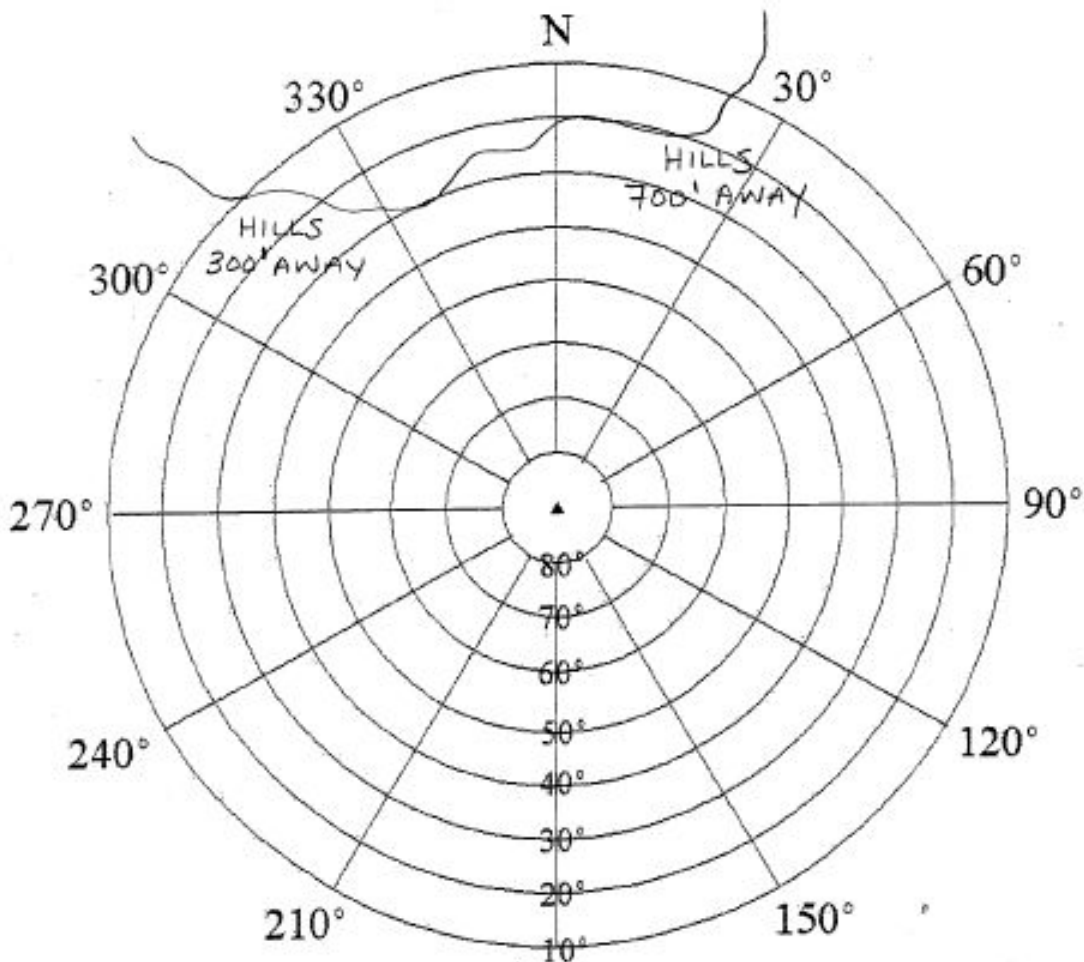

POINT # 103

DATE: 04/26/07

**INSTRUCTIONS:**

Identify obstructions by azimuth (magnetic) and elevation angle (above horizon) as seen from the point. Indicate distance and direction to nearby structures and reflective surfaces (potential multipath sources).

Check if no obstructions above 10 degrees







North



South





East



West

**TOWN OF CHINO VALLEY CONTROL NETWORK**

**POINT NAME: 104**

**MONUMENT FIELD VISIT INFORMATION**

DATE OF FIELD VISIT 4/26/2007  
 LEFT AS FOUND     FOUND & TAGGED     FOUND & REBUILT     RESTORED LOST CORNER  
 RESTORED OBLITERATED CORNER     ESTABLISHED NEW MONUMENT

ARIZONA STATE PLANE COORDINATE SYSTEM:

ZONE:     WEST     CENTRAL     EAST  
 N.A.D. 1927 (FEET)     N.A.D. 1983 (FEET)     W.G.S. 1984 (METERS)  
 N.A.V.D. 1929 (FEET)     N.A.V.D. 1988 (FEET)    ELLIPSOID HEIGHT 4908.622  
N. (OR) Y = 1373492.642    E. (OR) X = 582834.377    ELEVATION 4992.903  
LATITUDE 34°46'28.56092"N    LONGITUDE 112°18'24.62208"W    GRID FACTOR \_\_\_\_\_  
CONTROL STATIONS USED: AZAH, AZPE, FST1

DESCRIBE ALL EVIDENCE FOUND, INCLUDING TIES AND ACCESSORIES TO COMPLY WITH ARIZONA REVISED STATUTE TITLE 33, SECTION 106

STATIC OBSERVATION 99% CONFIDENCE LEVEL

SEE THE TOWN OF CHINO VALLEY CONTROL NETWORK DATUM DEFINITION FOR COMBINED GRID FACTOR AND THE NORTHING AND EASTING OFFSET INFORMATION.

MONUMENT CAP STAMPING

**CORNER LOCATION INFORMATION**

TOWNSHIP 16 N    RANGE 1 W  
SECTION 12  
GILA & SALT RIVER    MERIDIAN YAVAPAI    COUNTY \_\_\_\_\_  
FORMAL MONUMENT NAME 104

ALIQUOT GOV'T COR.     NON-ALIQUOT GOV'T COR.     OTHER

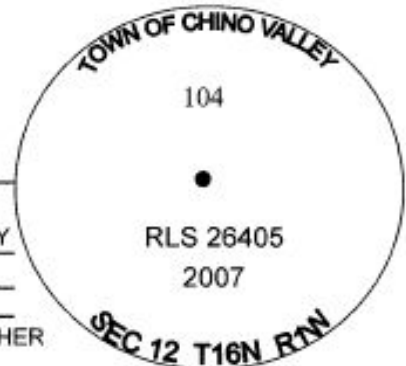



**POINT # 104**

**DATE: APRIL 26, 2007**

**DIRECTIONS:**

- From the intersection of Hwy 89 and 89A head NORTH on Hwy 89 for 9.6 miles to Perkinsville Rd.
- Turn EAST (right) for 8.3 miles where Perkinsville turns northeast, at "Y" bear right onto smaller dirt road for 0.5 miles to point
- Monument is 3 1/4 inch aluminum disk flush set in concrete, 80 feet north of fence intersection and section corner, 7 feet west of fence line

**SKETCH**

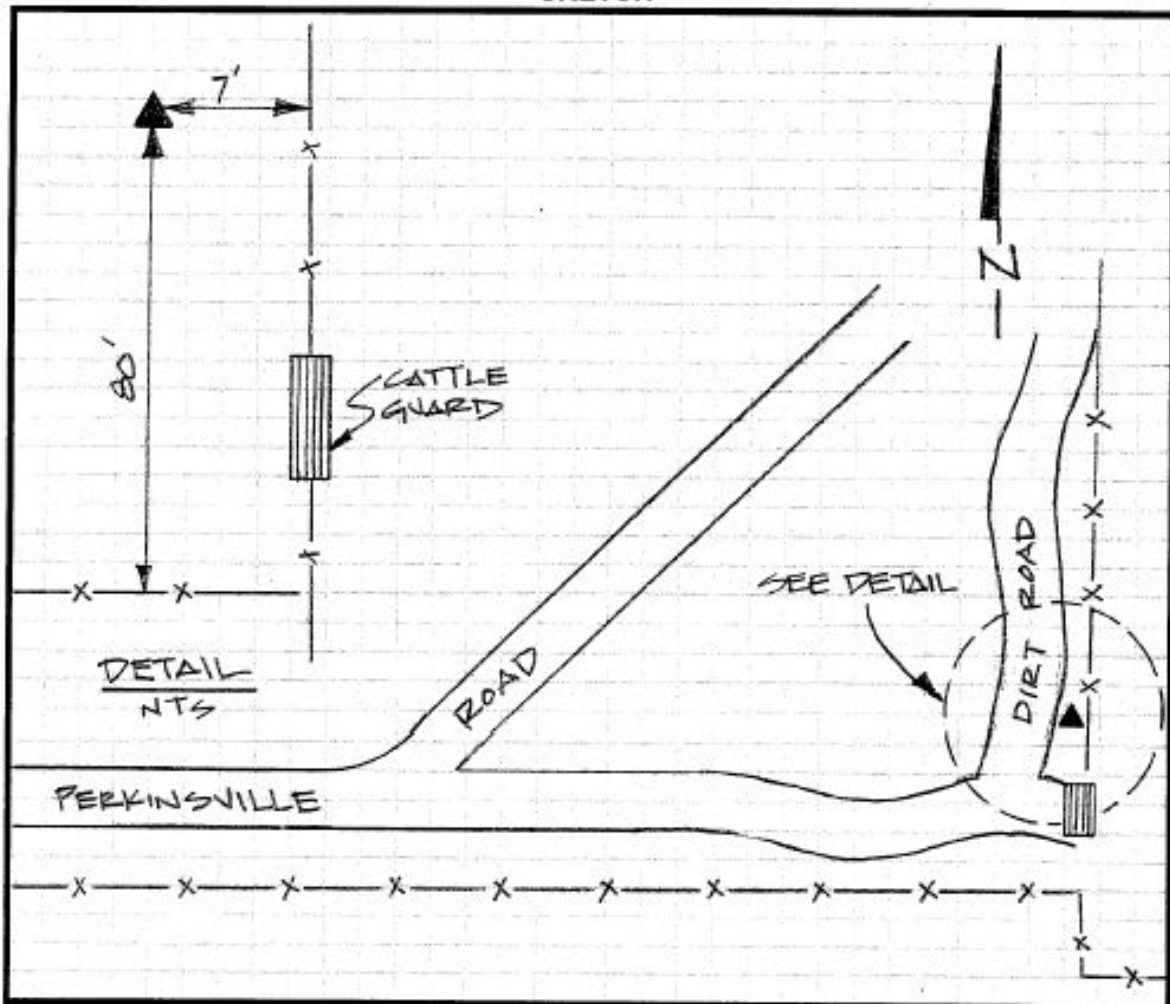

TOWN OF CHINO VALLEY CONTROL NETWORK

OBSTRUCTION CHART

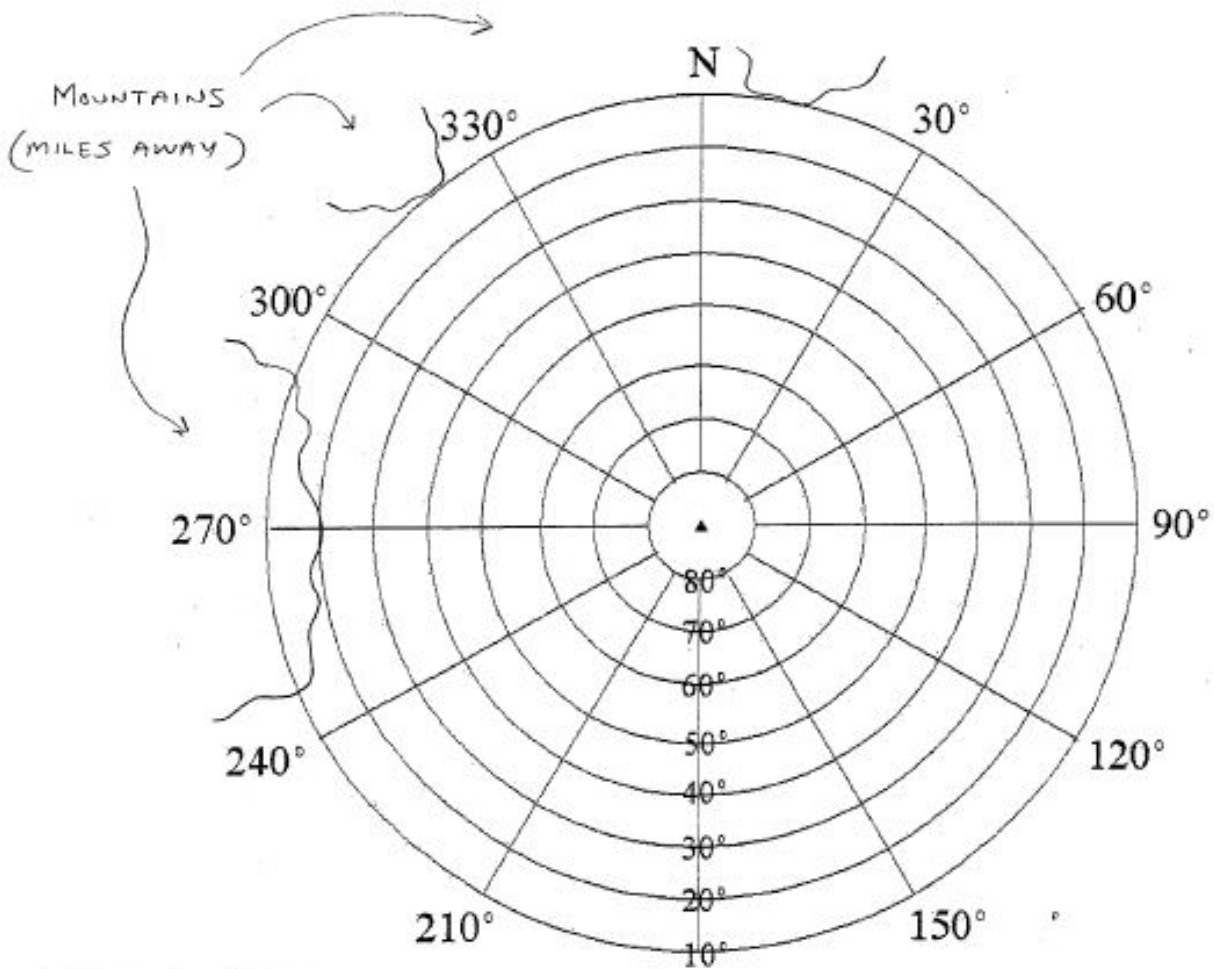

POINT # 104

DATE: 04/26/07

INSTRUCTIONS:

Identify obstructions by azimuth (magnetic) and elevation angle (above horizon) as seen from the point. Indicate distance and direction to nearby structures and reflective surfaces (potential multipath sources).

Check if no obstructions above 10 degrees







North



South



East



West



**TOWN OF CHINO VALLEY CONTROL NETWORK**

**POINT NAME: 105**

**MONUMENT FIELD VISIT INFORMATION**

DATE OF FIELD VISIT 4/26/2007  
 LEFT AS FOUND     FOUND & TAGGED     FOUND & REBUILT     RESTORED LOST CORNER  
 RESTORED OBLITERATED CORNER     ESTABLISHED NEW MONUMENT

ARIZONA STATE PLANE COORDINATE SYSTEM:

ZONE:     WEST     CENTRAL     EAST  
 N.A.D. 1927 (FEET)     N.A.D. 1983 (FEET)     W.G.S. 1984 (METERS)  
 N.A.V.D. 1929 (FEET)     N.A.V.D. 1988 (FEET)    ELLIPSOID HEIGHT 4690.893  
N. (OR) Y = 1390683.263    E. (OR) X = 524683.577    ELEVATION 4776.445  
LATITUDE 34°49'15.81350"N    LONGITUDE 112°30'02.92631"W    GRID FACTOR \_\_\_\_\_  
CONTROL STATIONS USED: AZAH, AZPE, FST1

DESCRIBE ALL EVIDENCE FOUND, INCLUDING TIES AND ACCESSORIES TO COMPLY WITH ARIZONA REVISED STATUTE TITLE 33, SECTION 106

STATIC OBSERVATION 99% CONFIDENCE LEVEL

SEE THE TOWN OF CHINO VALLEY CONTROL NETWORK DATUM DEFINITION FOR COMBINED GRID FACTOR AND THE NORTHING AND EASTING OFFSET INFORMATION.

MONUMENT CAP STAMPING

**CORNER LOCATION INFORMATION**

TOWNSHIP 17 N    RANGE 2 W  
SECTION 12  
GILA & SALT RIVER    MERIDIAN YAVAPAI    COUNTY \_\_\_\_\_  
FORMAL MONUMENT NAME 105

ALIQUOT GOV'T COR.     NON-ALIQUOT GOV'T COR.     OTHER

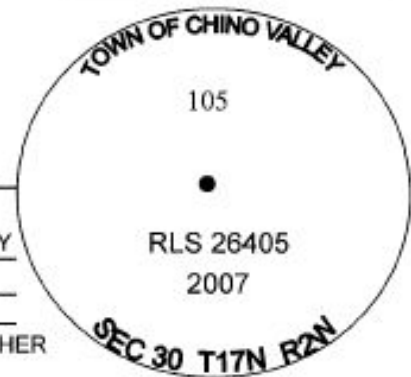



TOWN OF CHINO VALLEY CONTROL NETWORK

OBSTRUCTION CHART

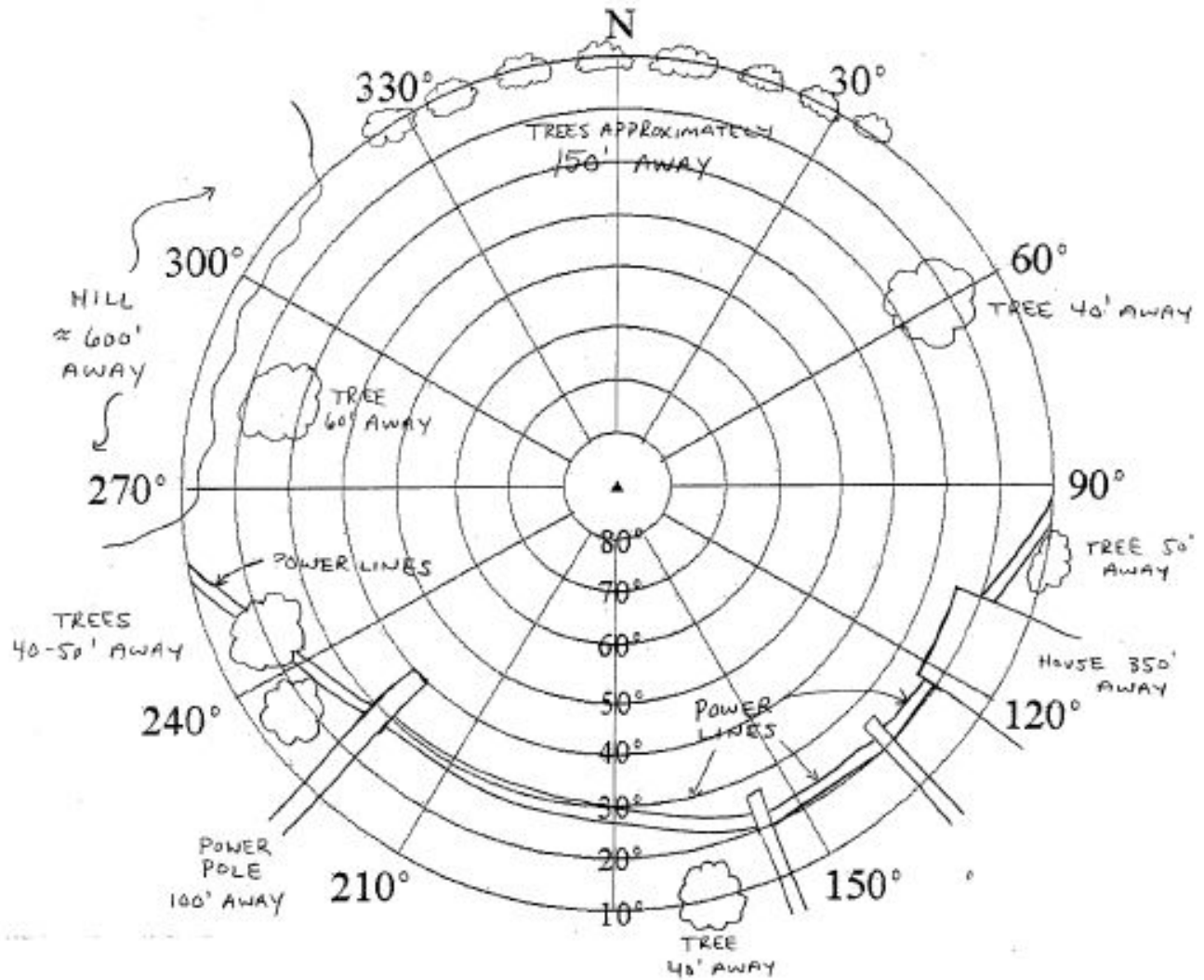

POINT # 105

DATE: 04/26/07

INSTRUCTIONS:

Identify obstructions by azimuth (magnetic) and elevation angle (above horizon) as seen from the point. Indicate distance and direction to nearby structures and reflective surfaces (potential multipath sources).

Check if no obstructions above 10 degrees









North



South



East



West



**TOWN OF CHINO VALLEY CONTROL NETWORK**

**POINT NAME: 106**

**MONUMENT FIELD VISIT INFORMATION**

DATE OF FIELD VISIT 4/26/2007  
 LEFT AS FOUND     FOUND & TAGGED     FOUND & REBUILT     RESTORED LOST CORNER  
 RESTORED OBLITERATED CORNER     ESTABLISHED NEW MONUMENT

ARIZONA STATE PLANE COORDINATE SYSTEM:

ZONE:     WEST     CENTRAL     EAST  
 N.A.D. 1927 (FEET)     N.A.D. 1983 (FEET)     W.G.S. 1984 (METERS)  
 N.A.V.D. 1929 (FEET)     N.A.V.D. 1988 (FEET)    ELLIPSOID HEIGHT 4312.800  
N. (OR) Y = 1412431.002    E. (OR) X = 534717.96    ELEVATION 4397.857  
LATITUDE 34°52'51.49201"N    LONGITUDE 112°28'04.00248"W    GRID FACTOR \_\_\_\_\_  
CONTROL STATIONS USED: AZAH, AZPE, FST1

DESCRIBE ALL EVIDENCE FOUND, INCLUDING TIES AND ACCESSORIES TO COMPLY WITH ARIZONA REVISED STATUTE TITLE 33, SECTION 106

STATIC OBSERVATION 99% CONFIDENCE LEVEL

SEE THE TOWN OF CHINO VALLEY CONTROL NETWORK DATUM DEFINITION FOR COMBINED GRID FACTOR AND THE NORTHING AND EASTING OFFSET INFORMATION.

MONUMENT CAP STAMPING

**CORNER LOCATION INFORMATION**

TOWNSHIP 17 N    RANGE 2 W  
SECTION 3  
GILA & SALT RIVER    MERIDIAN YAVAPAI    COUNTY \_\_\_\_\_  
FORMAL MONUMENT NAME 106

ALIQUOT GOV'T COR.     NON-ALIQUOT GOV'T COR.     OTHER

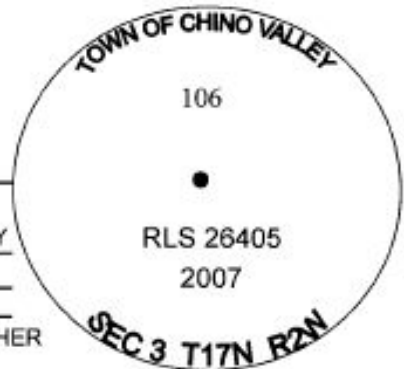



**POINT # 106**

**DATE: APRIL 26, 2007**

**DIRECTIONS:**

- From the intersection of Hwy 89 and 89A head NORTH on Hwy 89 for 17.2 miles to Old Hwy 89.
- Turn EAST (right) for +/- 150 feet.
- Turn NORTH (left) onto dirt path
- Monument is 3/4 inch aluminum disk flush set in concrete, 170 feet north of cattle guard, 203 feet east of east edge of pavement of Hwy 89, 77 feet southeast of tree, and 10 feet west of fence, slightly elevated from dirt path.

**SKETCH**

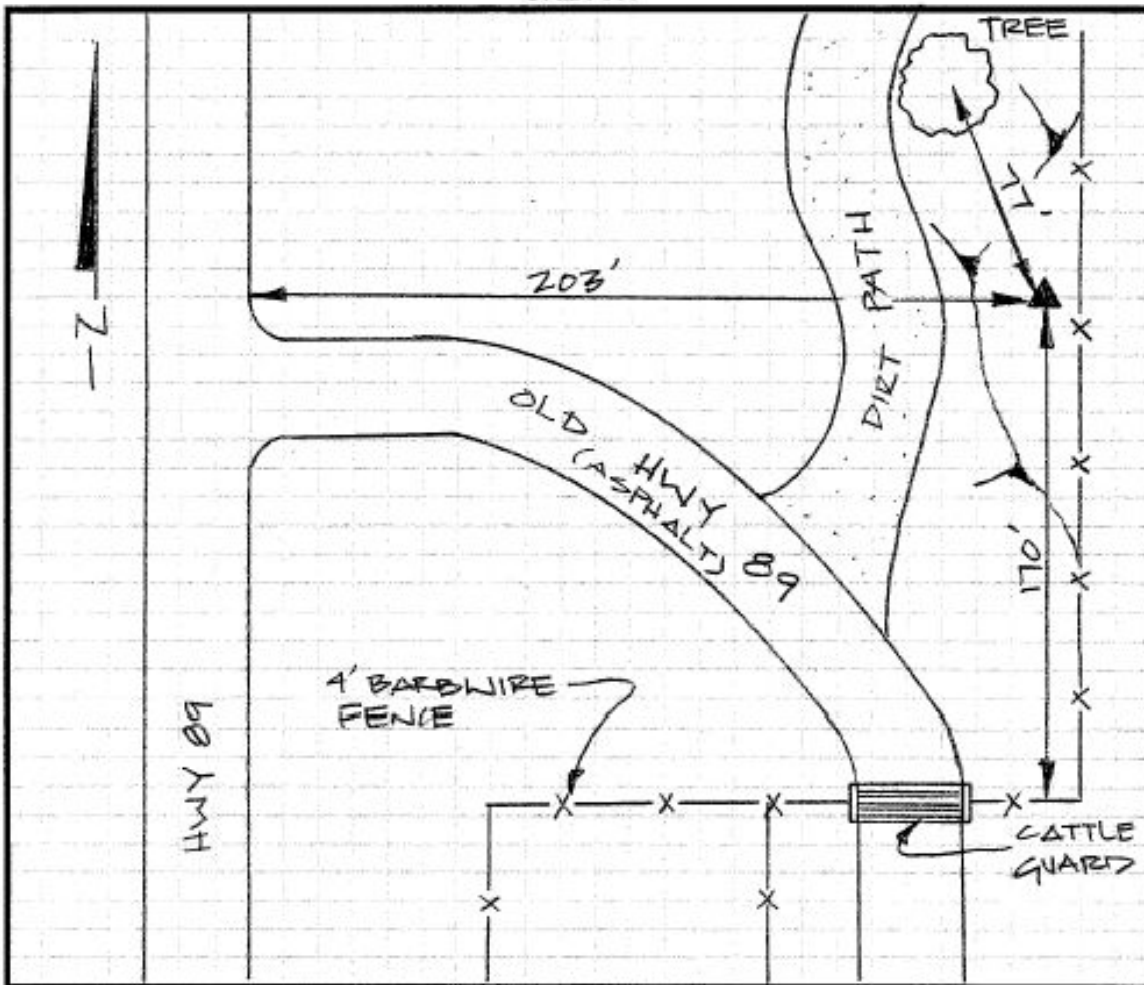

**TOWN OF CHINO VALLEY CONTROL NETWORK**

**OBSTRUCTION CHART**

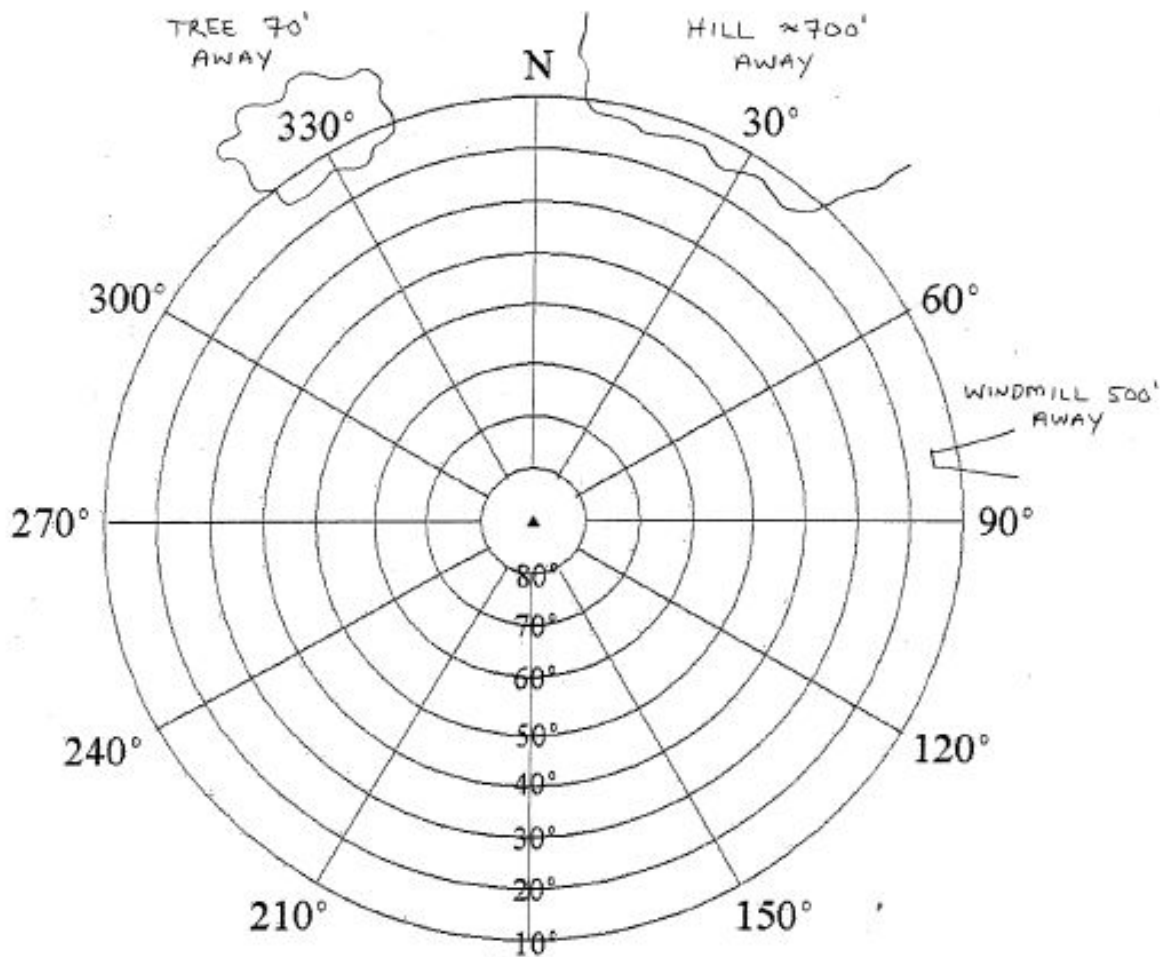

POINT # 106

DATE: 04/26/07

**INSTRUCTIONS:**

Identify obstructions by azimuth (magnetic) and elevation angle (above horizon) as seen from the point. Indicate distance and direction to nearby structures and reflective surfaces (potential multipath sources).

Check if no obstructions above 10 degrees







North



South





East



West

**TOWN OF CHINO VALLEY CONTROL NETWORK**

**POINT NAME: COTT**

**MONUMENT FIELD VISIT INFORMATION**

DATE OF FIELD VISIT 4/26/2007

LEFT AS FOUND     FOUND & TAGGED     FOUND & REBUILT     RESTORED LOST CORNER  
 RESTORED OBLITERATED CORNER     ESTABLISHED NEW MONUMENT

ARIZONA STATE PLANE COORDINATE SYSTEM:

ZONE:     WEST     CENTRAL     EAST

N.A.D. 1927 (FEET)     N.A.D. 1983 (FEET)     W.G.S. 1984 (METERS)

N.A.V.D. 1929 (FEET)     N.A.V.D. 1988 (FEET)    ELLIPSOID HEIGHT 4514.551

N. (OR) Y = 1378908.275    E. (OR) X = 539240.314    ELEVATION 4599.915

LATITUDE 34°47'20.14381"    LONGITUDE 112°27'07.57144    GRID FACTOR \_\_\_\_\_

CONTROL STATIONS USED: AZAH, AZPE, FST1

DESCRIBE ALL EVIDENCE FOUND, INCLUDING TIES AND ACCESSORIES TO COMPLY WITH ARIZONA REVISED STATUTE TITLE 33, SECTION 106

STATIC OBSERVATION 99% CONFIDENCE LEVEL

SEE THE TOWN OF CHINO VALLEY CONTROL NETWORK DATUM DEFINITION FOR COMBINED GRID FACTOR AND THE NORTHING AND EASTING OFFSET INFORMATION.

"COTT" COORDINATES WERE REESTABLISHED DURING THIS STATIC NETWORK. THE COORDINATES HEREIN WILL DIFFER FROM THE NGS PUBLISHED DATA.

MONUMENT CAP STAMPING

**CORNER LOCATION INFORMATION**

TOWNSHIP 16 N RANGE 2 W

SECTION 10

GILA & SALT RIVER MERIDIAN YAVAPAI COUNTY

FORMAL MONUMENT NAME COTT

ALIQUOT GOV'T COR.     NON-ALIQUOT GOV'T COR.     OTHER



**POINT # COTT**

**DATE: APRIL 26, 2007**

**DIRECTIONS:**

- From the intersection of Hwy 89 and 89A head NORTH on Hwy 89 for 10.8 miles to Road 4 North, at southwest corner of intersection.
- Monument is 4 inch brass disk, 84 feet south of Road 4 North centerline, 46 feet west of Hwy 89 centerline, 68 feet south of power pole, 55 feet east of fence line, 3 feet east of metal witness post, and 1.5 feet of a fiberglass witness post.

**SKETCH**

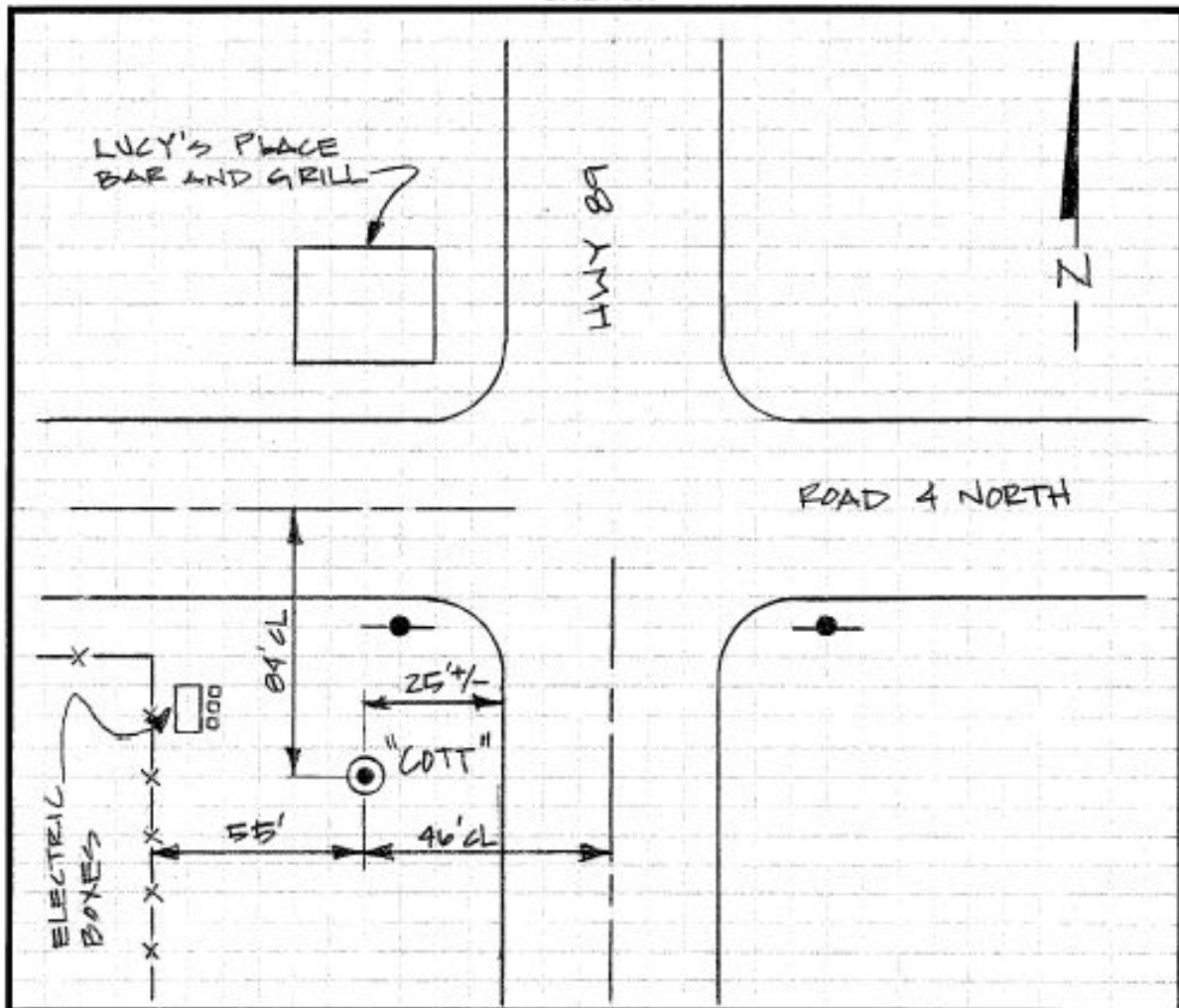

TOWN OF CHINO VALLEY CONTROL NETWORK

OBSTRUCTION CHART

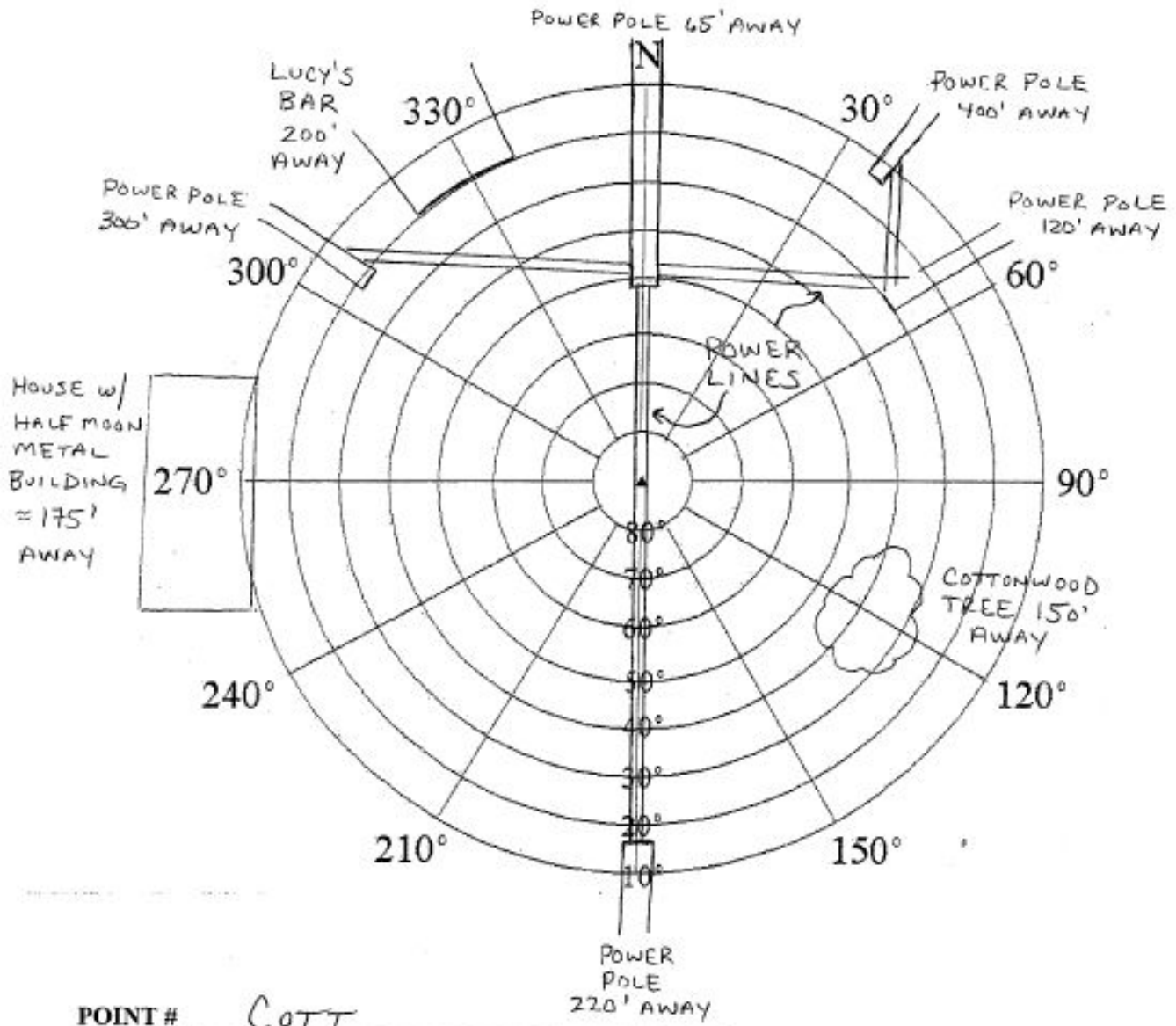

POINT # COTT

DATE: 04/26/07

INSTRUCTIONS:

Identify obstructions by azimuth (magnetic) and elevation angle (above horizon) as seen from the point. Indicate distance and direction to nearby structures and reflective surfaces (potential multipath sources).

Check if no obstructions above 10 degrees







North



South





East



West

**TOWN OF CHINO VALLEY CONTROL NETWORK**

**POINT NAME: PRESCOTT NORTH BASE RESET**

**MONUMENT FIELD VISIT INFORMATION**

DATE OF FIELD VISIT 4/26/2007  
 LEFT AS FOUND     FOUND & TAGGED     FOUND & REBUILT     RESTORED LOST CORNER  
 RESTORED OBLITERATED CORNER     ESTABLISHED NEW MONUMENT

ARIZONA STATE PLANE COORDINATE SYSTEM:

ZONE:     WEST     CENTRAL     EAST

N.A.D. 1927 (FEET)     N.A.D. 1983 (FEET)     W.G.S. 1984 (METERS)

N.A.V.D. 1929 (FEET)     N.A.V.D. 1988 (FEET)

ELLIPSOID HEIGHT 4448.275

N. (OR) Y = 1396887.811    E. (OR) X = 534880.55    ELEVATION 4533.538

LATITUDE 34°50'17.75598"    LONGITUDE 112°28'01.02667"    GRID FACTOR \_\_\_\_\_

CONTROL STATIONS USED: AZAH, AZPE, FSTI

DESCRIBE ALL EVIDENCE FOUND, INCLUDING TIES AND ACCESSORIES TO COMPLY WITH ARIZONA REVISED STATUTE TITLE 33, SECTION 108

STATIC OBSERVATION 99% CONFIDENCE LEVEL

SEE THE TOWN OF CHINO VALLEY CONTROL NETWORK DATUM DEFINITION FOR COMBINED GRID FACTOR AND THE NORTHING AND EASTING OFFSET INFORMATION.

"PRESCOTT NORTH BASE RESET" COORDINATES WERE REESTABLISHED DURING THIS STATIC NETWORK. THE COORDINATES HEREIN WILL DIFFER FROM THE NGS PUBLISHED DATA.

MONUMENT CAP STAMPING

**CORNER LOCATION INFORMATION**

TOWNSHIP 17 N    RANGE 2 W

SECTION 22

GILA & SALT RIVER    MERIDIAN YAVAPAI    COUNTY

FORMAL MONUMENT NAME PRESCOTT NORTH BASE RESET

ALIQUOT GOV'T COR.     NON-ALIQUOT GOV'T COR.     OTHER

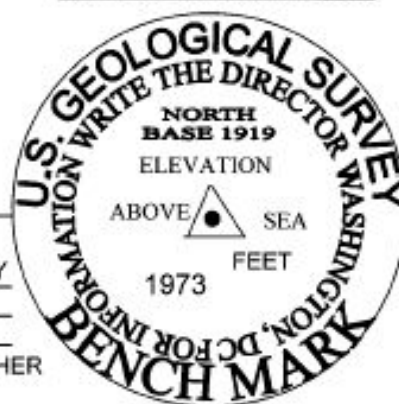



**POINT # PRESCOTT NORTH BASE RESET**

**DATE: APRIL 26, 2007**

**DIRECTIONS:**

- From the intersection of Hwy 89 and 89A head NORTH on Hwy 89 for 13.9 miles to Bethany Lane on the west and Old Hwy 89 on the east.
- Turn WEST (left) for 0.4 mile to small dirt road on right (north).
- Turn NORTH (left) for 0.3 mile to top of small hill.
- Monument is 4 inch brass disk stamped NORTH BASE 1919-1973, set in concrete.

**SKETCH**

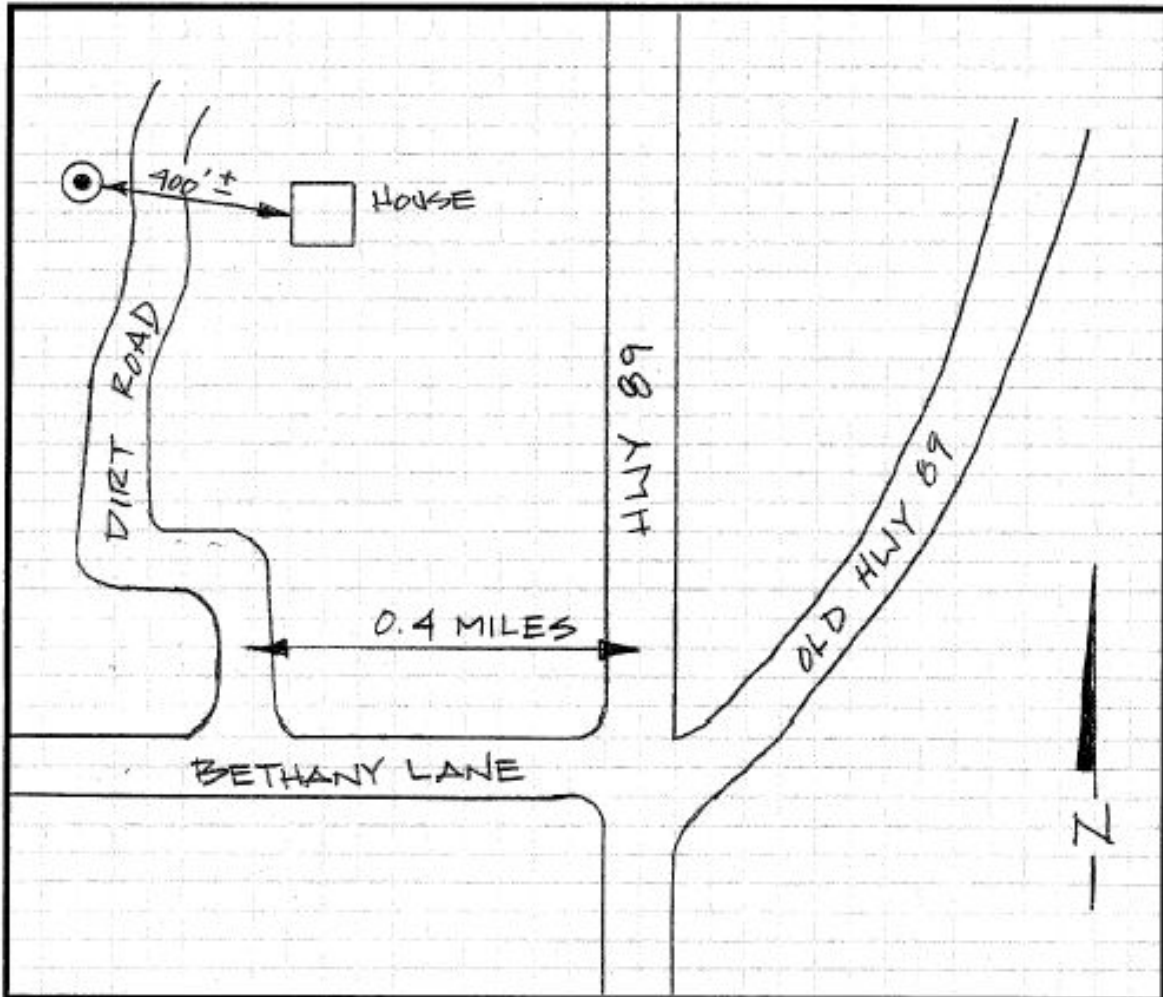

TOWN OF CHINO VALLEY CONTROL NETWORK

OBSTRUCTION CHART

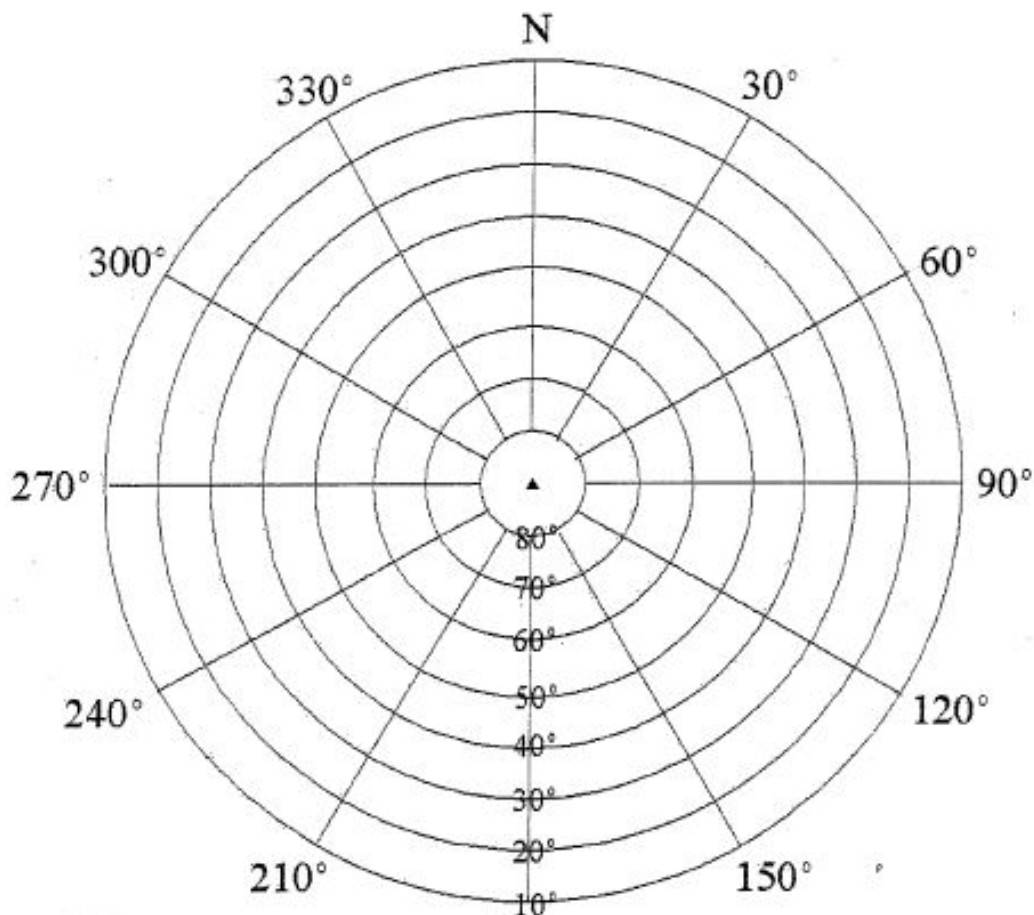

POINT # PRESCOTT NORTH BASE RESET

DATE: 04/26/07

INSTRUCTIONS:

Identify obstructions by azimuth (magnetic) and elevation angle (above horizon) as seen from the point. Indicate distance and direction to nearby structures and reflective surfaces (potential multipath sources).

Check if no obstructions above 10 degrees







North



South





East



West

**TOWN OF CHINO VALLEY CONTROL NETWORK**

**POINT NAME: PRESCOTT SOUTH BASE**

**MONUMENT FIELD VISIT INFORMATION**

DATE OF FIELD VISIT 4/26/2007

LEFT AS FOUND     FOUND & TAGGED     FOUND & REBUILT     RESTORED LOST CORNER  
 RESTORED OBLITERATED CORNER     ESTABLISHED NEW MONUMENT

ARIZONA STATE PLANE COORDINATE SYSTEM:

ZONE:     WEST     CENTRAL     EAST

N.A.D. 1927 (FEET)     N.A.D. 1983 (FEET)     W.G.S. 1984 (METERS)

N.A.V.D. 1929 (FEET)     N.A.V.D. 1988 (FEET)

ELLIPSOID HEIGHT 4932.008

N. (OR) Y = 1346331.865

E. (OR) X = 549153.18

ELEVATION 5017.758

LATITUDE 34°41'58.41362"

LONGITUDE 112°25'06.76655"

GRID FACTOR \_\_\_\_\_

CONTROL STATIONS USED: AZAH, AZPE, FST1

DESCRIBE ALL EVIDENCE FOUND, INCLUDING TIES AND ACCESSORIES TO COMPLY WITH ARIZONA REVISED STATUTE TITLE 33, SECTION 106

STATIC OBSERVATION 99% CONFIDENCE LEVEL

SEE THE TOWN OF CHINO VALLEY CONTROL NETWORK DATUM DEFINITION FOR COMBINED GRID FACTOR AND THE NORTHING AND EASTING OFFSET INFORMATION.

"PRESCOTT SOUTH BASE" COORDINATES WERE REESTABLISHED DURING THIS STATIC NETWORK. THE COORDINATES HEREIN WILL DIFFER FROM THE NGS PUBLISHED DATA.

MONUMENT CAP STAMPING

**CORNER LOCATION INFORMATION**

TOWNSHIP 15 N RANGE 2 W

SECTION 12

GILA & SALT RIVER MERIDIAN

YAVAPAI COUNTY

FORMAL MONUMENT NAME PRESCOTT SOUTH BASE

ALIQUOT GOV'T COR.     NON-ALIQUOT GOV'T COR.     OTHER





**POINT # PRESCOTT SOUTH BASE**

**DATE: APRIL 26, 2007**

**DIRECTIONS:**

- From the intersection of Hwy 89 and 89A head NORTH on Hwy 89 for 3.3 miles, pass overhead transmission lines to gate on right (east) side of highway.
- Turn EAST (right) go through gate, for 1.2 miles along transmission lines, cross small wash with old bridge to "Y"
- Turn NORTH (left) for 0.2 mile to "Y".
- Turn EAST (left) for 0.7 mile to station located in middle of a turnaround at highest point of a low ridge.
- Monument is 4 inch brass disk stamped SOUTH BASE 1919 set in concrete.

**SKETCH**

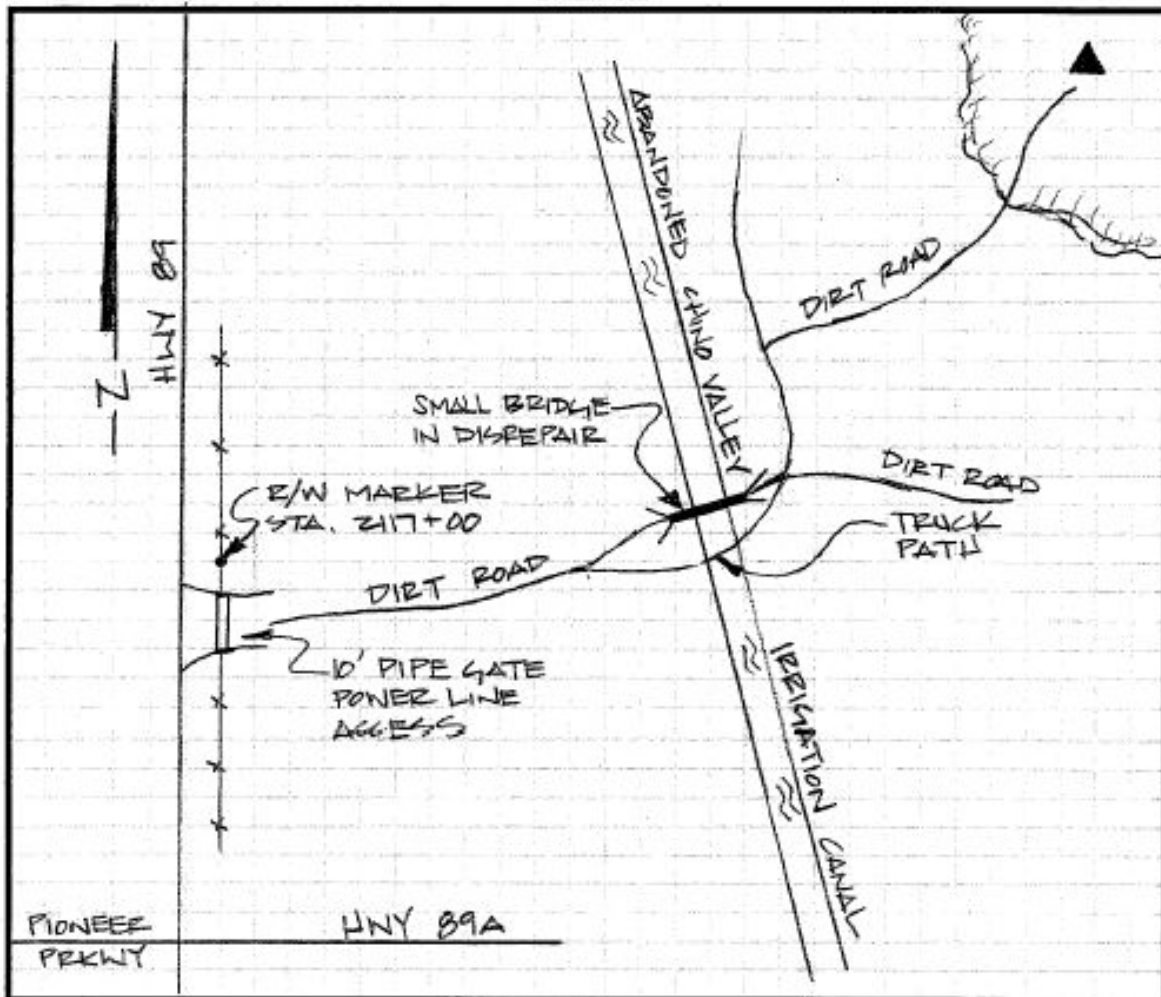

TOWN OF CHINO VALLEY CONTROL NETWORK

OBSTRUCTION CHART

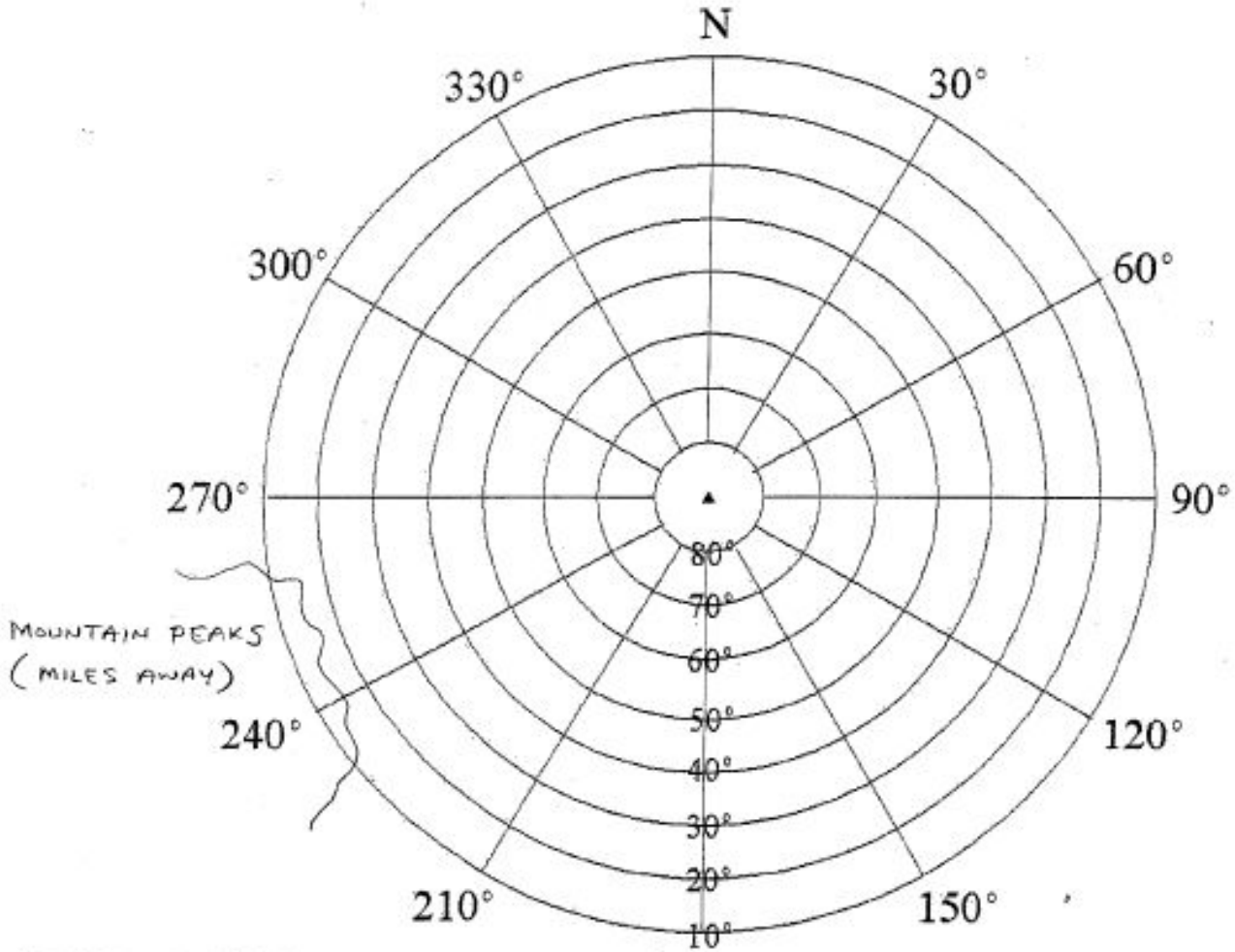

POINT # PRESCOTT SOUTH BASE

DATE: 04/26/07

INSTRUCTIONS:

Identify obstructions by azimuth (magnetic) and elevation angle (above horizon) as seen from the point. Indicate distance and direction to nearby structures and reflective surfaces (potential multipath sources).

Check if no obstructions above 10 degrees

1







North



South



East



West

# TOWN OF CHINO VALLEY

## DATUM CONVERSION SPREADSHEET



Name	NAD83 (Conus)			State Plane Coordinates (Meters)		NAVD88 Elevation
	Latitude	Longitude	Height	AZ Central Zone (epoch 2002) Northing	Eastings	
2	34°38'08.42846"N	112°25'05.42942"W	4923.22	403275.370	167380.634	1526.856
4	34°53'49.23579"N	112°28'12.05432"W	4311.45	432289.395	162787.408	1340.029
100	34°43'18.59808"N	112°19'42.74290"W	4807.92	412795.209	175637.726	1491.313
101	34°44'43.75422"N	112°29'01.61447"W	4746.35	415488.310	161434.201	1472.829
102	34°45'11.20221"N	112°24'44.21281"W	4728.21	416299.457	167985.108	1467.166
103	34°47'23.68341"N	112°22'38.37938"W	4655.06	420366.368	171203.962	1444.708
104	34°46'28.56092"N	112°18'24.62208"W	4908.62	418640.557	177647.918	1521.837
105	34°49'15.81350"N	112°30'02.92631"W	4690.89	423880.258	159923.554	1455.860
106	34°52'51.49201"N	112°28'04.00248"W	4312.80	430508.969	162982.034	1340.467
COTT	34°47'20.14381"N	112°27'07.57144"W	4514.55	420291.242	164360.448	1402.054
Prescott North Base Reset	34°50'17.75598"N	112°28'01.02667"W	4448.28	425771.405	163031.592	1381.822
Prescott South Base	34°41'58.41362"N	112°25'06.76655"W	4932.01	410361.952	167381.889	1529.413
AZAH	33°46'28.03114"N	111°53'30.78646"W	2338.67	307638.886	215655.241	
AZPE	33°34'29.77661"N	112°15'20.16135"W	1040.57	285562.763	181895.657	
FST1	35°13'18.37069"N	111°49'02.58156"W	7011.51	468179.974	222397.931	

State Plane Coordinates AZ Central, epoch 2002 (NAD83 2002) to Chino Valley Survey Datum (CVSD)

Name	State Plane Coordinates (International Feet)			Town of Chino Valley Survey Datum		
	AZ Central Zone (epoch 2002) Northing	Eastings	NAVD88 Elevation	Northing	Eastings	Elevation
Centroid	1367800.000	551400.000	4743	368206.355	151563.814	4743
2	1323081.922	549149.060	5009.37	323474.992	149312.205	5009.37
4	1418272.293	534079.423	4396.42	418693.643	134238.091	4396.42
100	1354314.992	576239.258	4892.76	354717.341	176410.451	4892.76
101	1363150.624	529639.768	4832.12	363555.598	129797.117	4832.12
102	1365811.867	551132.245	4813.54	366217.632	151295.979	4813.54
103	1379154.752	561692.789	4739.86	379564.481	161859.661	4739.86
104	1373492.642	582834.377	4992.90	373900.689	183007.529	4992.90
105	1390683.263	524683.577	4776.45	391096.417	124839.454	4776.45
106	1412431.002	534717.960	4397.86	412850.617	134876.818	4397.86
COTT	1378908.275	539240.314	4599.92	379317.931	139400.515	4599.92
Prescott North Base Reset	1396887.811	534880.550	4533.54	397302.808	135039.456	4533.54
Prescott South Base	1346331.865	549153.180	5017.76	346731.843	149316.326	5017.76

# CONTROL MONUMENT LOCATION MAP